



INSTRUCTION

GREASE BUCKET PUMP

SK-55 ITEM No.880307

SK-77 ITEM No.880308



880307
SK-55



880308
SK-77

WARNING

Prior to operating this pump, be sure to read this operation manual for safety. After reading the manual, please keep it at hand any time for your quick reference.

YAMADA CORPORATION

- Preface

Thank you for purchasing a Yamada Pump. This is a hand operated lever type pump suitable for grease up to NLGI No.0. The machine can keep a large quantity of grease in its cabinet and is most suitable for lubrication work in an outdoor place where no compressor is available. Use of high viscosity grease will produce air pockets and result in operation failure.

- For Safe Operation

This manual describes the items that are important for the user to operate this product safely, correctly, and efficiently. Before operating this product, read this manual thoroughly, in particular, "Warnings and Cautions" at the beginning of this manual.

- Warnings and Cautions

For safe use of this product, be sure to note the following: In this document, warnings and cautions are indicated by symbols. These symbols are for those who will operate this product and for those who will be nearby, for safe operation and for prevention of personal injury and property damage. The following warning and caution symbols have the meanings described below. Be sure to remember their meanings.



WARNING : This indicates the existence of potential hazard which, if not avoided, will result in death or serious injury.



CAUTION : This indicates the existence of potential hazard which, if not avoided, may result in bodily injury or in physical damage.

Furthermore, to indicate the type of danger and damage, the following symbols are also used along with those mentioned above:





This symbol indicates a DON'T, and will be accompanied by an explanation on something you must not do.



This symbol indicates a DO, and will be accompanied by instructions on something you must do in a certain situation.

- Precautions on Use

The following warnings and cautions are very important. Be sure to observe them.

 WARNING	
	- Gasoline is a high-volatility fuel. Do not use it to clean the pump in any case. Otherwise, ignition or explosion may be caused.
	- Some types of grease to be used may contain carcinogens. Read the precautions provided by grease manufacturer thoroughly and handle the grease with care.



 CAUTION	
	- This pump is suitable only for grease. Do not use any other solvents.
	- Use of high viscosity grease will produce air pockets and result in operation failure. Do not use anything harder than No.0 grease. If you would like to use high viscosity grease, please contact our business office.

Table of Contents

- Preface	
- For Safe Operation	
- Warnings and Cautions	
- Precautions on Use	
1. Names and Materials of Parts	
1.1 Names and Materials of Parts	1
1.2 Contents of Package	1
2. Preparations before Operation	1
3. How to Operate the Machine	2
4. Maintenance and Inspection	
4.1 Troubleshooting and Corrective Measures	3
4.2 Maintenance and Inspection	3
5. Disassembly and Assembly	3
6. Parts Disassembly Drawing and Parts List	
6.1 880307(SK-55)、880308(SK-77) Grease Bucket Pump	4
7. Specification	5
8. Limited Warranty	6

1. Names and Materials of Parts

1.1 Names and Materials of Parts

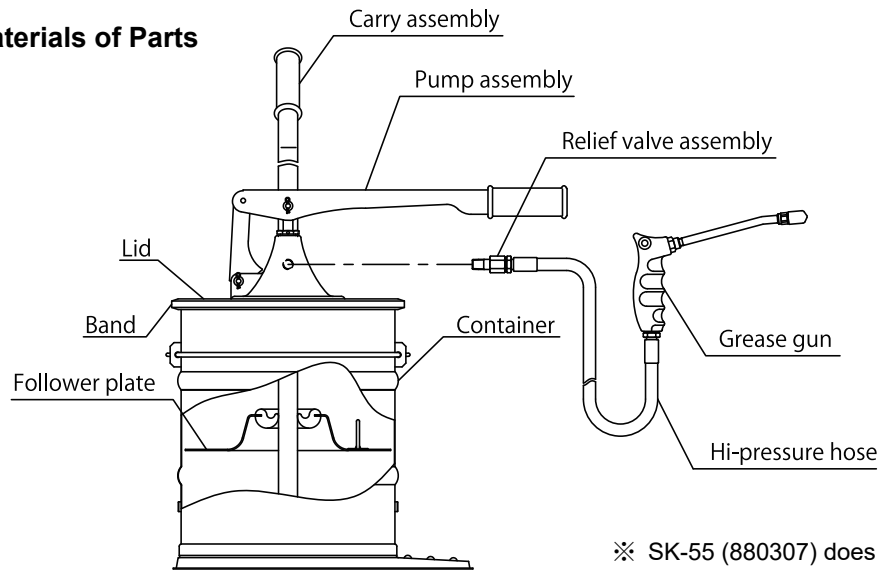

※ SK-55 (880307) does not include carry assembly (851003).

1.2 Contents of Package

The main unit and accessories are packed separately in the box.

Please make sure no damage during shipment and no missing accessories after unpacking as soon as possible.

Please make sure no loose screws, piping connections, and fastener components.

Please retighten if any screws, piping connections, and fastener components are loose.

2. Preparations before Operation

⚠ CAUTION



- Apply sealing compound or sealing tapes to the male screws and tighten tightly when the pipes are connected.
- Be careful not to allow the sealing materials to enter the piping.
(However, no applying is necessary if it will be connected to the hose union.)
- Check that there is no leakage from each part after connecting the piping.

<Assembly>

- 1) Connect high pressure hose and grease gun to the grease discharge port of pump assembly and tighten with a wrench.

Fig. 1

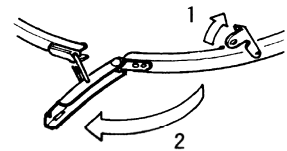

<To Fill Container>

- 2) Loosen stopper and draw latch to remove band. (Fig.1)
- 3) Separate lid together with pump assembly from container.
- 4) Remove follower plate from container.

<NOTE>

Prevent dirt particles from being sucked into the suction port or stuck to follower plate.

- 5) Wipe off container with a clean cloth before filling it with grease. (Fig.2)
Pour grease into container while being careful not to mix dirt particles into lubricant.
- 6) Smooth the surface of grease and then place follower plate on it in the

Fig. 2



- 7) Wipe suction port of pump assembly and insert it into the center hole in follower plate to place lid on container.(Fig.3)
- 8) Secure lid by tightening stopper and draw latch. In this time, set lever at appropriate position.
- 9) Push lever up and down several times so that grease will come out of gun. Initially discharged grease often contains air and is in poor condition. Discharge grease for a while until it becomes satisfactory.

<NOTE>

Air-containing grease is cloudy white.

<To Use Grease Pail>

This pump directly fits onto a grease pail.(Fig.4) In that case, follow the procedure described below instead of sec. 2. 2) - 2. 8).

- 1) If your grease pail has a carry handle, separate it from pail by unscrewing thumbscrews.
- 2) Loosen stopper and latch securing lid to pail.
- 3) Remove lid from grease pail.
- 4) Smooth the surface of grease and then place follower plate on it in the proper direction.
- 5) Remove pump lid together with pump assembly.
- 6) Wipe suction port of pump assembly and insert it into the center hole in follower plate to place lid on grease pail. (Fig.3)
- 7) Secure lid by tightening stopper and draw latch. In this time, set lever at appropriate position.
- 8) Attach carry handle to grease pail and tighten thumbscrews securely.

Fig. 3

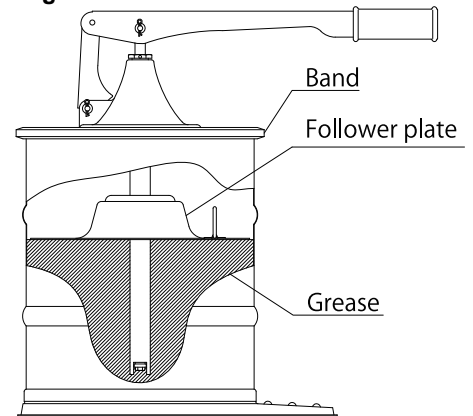

Fig. 4

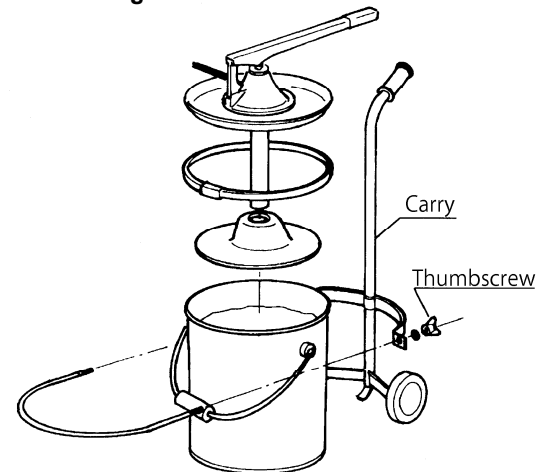
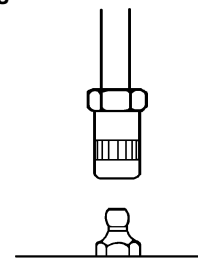
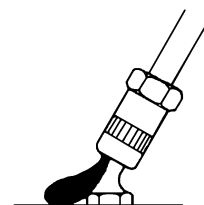

Fig. 5



- 1) Wipe grease gun coupler and grease nipple of equipment you are going to lubricate.
- 2) Press hydro coupler onto grease nipple in axial direction to connect them together. (Fig.5)
- 3) Hold grease gun and slowly move the lever up and down, stepping on the footboard to keep container from moving. When you push the lever down, fresh grease will come out of gun nozzle. Then, you will see old grease oozing out and when you see new grease following it out, stop supplying.
- 4) After lubrication, remove coupler from grease nipple by tilting it sideways. (Fig.6)

Fig. 6



4. Maintenance and Inspection

4.1 Troubleshooting and Corrective Measures

SYMPTOM	POSSIBLE CAUSE	CORRECTIVE MEASURE
Pump delivers no oil	Container is empty.	Fill container or replace grease pail.
	Follower plate is set incorrectly.	Check position and direction of follower plate.
	Pump malfunction	Inspect suction part.
Insufficient flow	Follower plate is set incorrectly.	Check position and direction of follower plate.
	Pump malfunction	Inspect suction part.
Oil leaks from gland	Wear-out of gland packing.	Tighten gland or replace packing.

4.2 Maintenance and Inspection

- ※If the lever becomes stiff, loosen gland a little and place a few drops of oil on it. (Fig.7)
- ※Check hose periodically and replace it if it is aged or leaking.

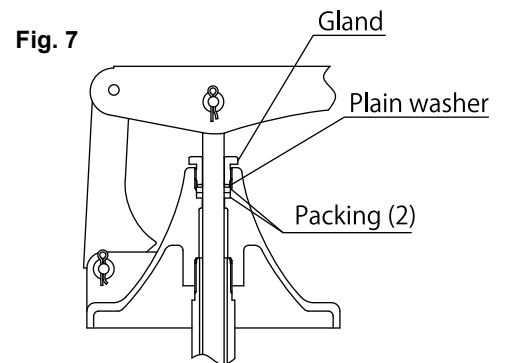

5. Disassembly and Assembly

⚠ CAUTION	
	- Gasoline is a high-volatility fuel. Do not use it to clean the pump in any case. Otherwise, ignition or explosion may be caused.

[Disassembly and Inspection of Suction Part]

- 1) Remove high pressure hose.
- 2) Loosen stopper and latch securing lid and separate pump assembly together with lid.
- 3) Unscrew three screws on the back of lid to separate pump assembly from lid.
- 4) Secure knurled section of suction tube in a vise.
- 5) Loosen nut on the lower part of cylinder.
- 6) Unscrew cylinder with a wrench to separately remove piston, valve, packing, tightening screw, and triangle ring. (Fig.8)
- 7) Wash and check each part. Replace damaged or worn parts with new ones.
- 8) Reverse the disassemble procedure to reassemble suction part while being certain that each part is attached in the correct direction.

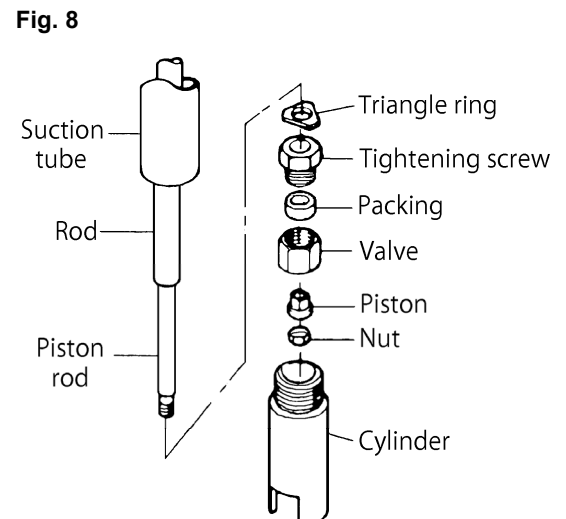

6. Parts Disassembly Drawing and Parts List

6.1 880307(SK-55)、880308(SK-77) Grease Bucket Pump

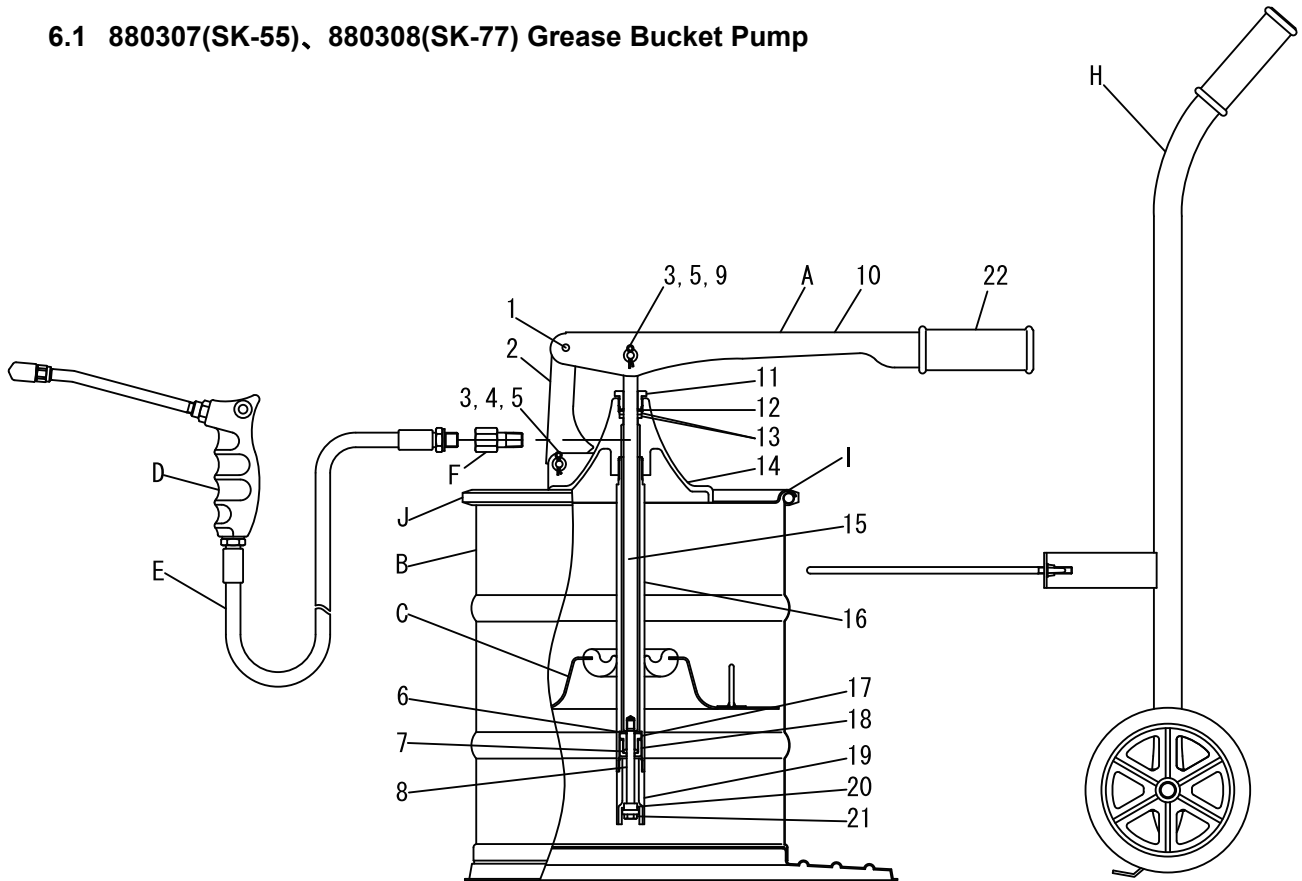

GREASE BUCKET PUMP PARTS LIST

No.	Description	Q'ty	Part No.	
			SK-55	SK-77
A	PUMP ASSEMBLY	1	851111	←
B	CONTAINER	1	830966	←
C	FOLLOWER PLATE	1	801426	←
D	GREASE GUN	1	800601	←
E	HI-PRESSURE HOSE	1	695046	←
F	RELIEF VALVE	1	800600	←
H	CARRY ASSEMBLY	1	-	851003
I	LID	1	707230	←
J	BAND	1	680456	←

851111 PUMP ASSEMBLY PARTS LIST

No.	Part No.	Description	Q'ty
1	702531	PIN	1
2	703182	LINK	1
3	631012	PLAIN WASHER	2
4	703574	PIN	1
5	680608	SNAP PIN	2
6	703183	TRIANGLE RING	1
7	770332	PACKING	1
8	715805	PISTON ROD	1
9	703580	PIN	1
10	703185	HANDLE	1
11	580994	GLAND	1
12	701755	PLAIN WASHER	2
13	770333	PACKING	1
14	708317	BODY	1
15	707234	ROD	1
16	708315	SUCTION TUBE	1
17	703188	GLAND	1
18	703189	VALVE	1
19	703190	CYLINDER	1
20	715804	PISTON	1
21	627290	NUT	1
22	770494	HANDLE GRIP	1

7. Specification

■ Engineering Data

Type	SK-55	SK-77
ITEM No.	880307	880308
Height	504 mm	795 mm
Mass(kg)	8.7 kg	11.3 kg
Container capacity	16 L	16 L
Accessories	800601 Grease gun 1 695046 High-pressure hose 1 801426 Follower plate 1	800601 Grease gun 1 695046 High-pressure hose 1 801426 Follower plate 1 851003 Carry assembly 1
Option	<p>If a grease nipple is located on narrow or hard-to-reach spaces or if a grease nipple is pin type or button head type, special micro hoses are available. Please purchase it separately.</p> <ul style="list-style-type: none"> • 850664 Micro hose assembly (SPK-1C) • 855205 Micro hose assembly (SPK-2C) • 850666 Micro hose assembly (SPK-3C) 	

Above conditions	Pump outlet pressure	25 MPa
Material Grease NLGI-No.0	Delivery	3.2 g/stroke
Oil Temperature 20 °C	Stroke	38 - 43 mm

8. Limited Warranty

If an abnormality occurs during normal operation in accordance with the operating instructions and other operating cautions within the warranty period (12 months after date of purchase) that can be attributed to a manufacturing defect, the defective parts of this product will be serviced or the product will be replaced free of charge. However, this warranty will not cover compensation for incidental damage or any malfunction listed below.

1. Warranty period

This warranty will be valid for a period of 12 months after the date of purchase.

2. Warranty

If, during the warranty period, any of the material of the genuine parts of this product or the workmanship of this product is found defective, and is so verified by our company, the servicing cost will be fully born by our company.

3. Exclusion

Even during the warranty period, this warranty does not cover the following.

- 1) Malfunction arising from use of parts other than manufacturer-specified genuine parts
- 2) Malfunction arising from misuse or operating errors, or lack of storage or maintenance care
- 3) Malfunction arising from use with a fluid that may cause corrosion, inflation or dissolution of the component parts of the product
- 4) Irregularity arising from repair made by other than by our firm, our regional office, dealer or authorized service personnel
- 5) Malfunction arising from modification of the product by other than authorized service personnel
- 6) Wear and tear of parts that must be regularly replaced in the course of normal operation, such as packings, O-rings and hose.
- 7) Malfunction and/or damage due to use with incorrect voltage.
- 8) Malfunction and/or damage due to transportation, moving or drop page of the product after purchase
- 9) Malfunction and/or damage due to fire, earthquake, flood or other force majeure
- 10) Malfunction arising from use of compressed air that contains impurities or excessive moisture, or use of gases or fluids other than the specified compressed air
- 11) Malfunction arising from use of excessively abrasive material or of inadequate grease.

Furthermore, this warranty does not cover the rubber parts, or other parts used in this product and its accessories, which are subject to wear in normal operation.

- hoses
- packings
- cords

4. Parts

Parts for this product will be kept available for 5 years after discontinuation of production. Once 5 years have elapsed after close of production, availability of parts for this product cannot be guaranteed.

MEMO.

YAMADA CORPORATION

INTERNATIONAL DEPARTMENT

1-1-3, Minami-Magome, Ota ku, Tokyo, 143-8504, Japan

PHONE : +81-(0)3-3777-0241

FAX : +81-(0)3-3777-0584

E-mail : intl@yamadacorp.co.jp

Web : www.yamadacorp.co.jp

YAMADA (THAILAND) CO., LTD

41/79 Moo 6, Bangcha-long, Bangplee, Sumutprakarn 10540, Thailand

PHONE : +66-(0)2-130-0990

FAX : +66-(0)2-130-0993

E-mail : sales@yamada-th.com